



Ghost

Kids' Ride on Car

Installation and Operation Instructions



Please read this instruction manual carefully. It is important to read and follow all of the steps during assembly to ensure proper operation and safety of the child. Please keep this manual for future reference.



**Scan this QR Code
to view the
Assembly Video**

SPECIFICATIONS:

Car Type:	SUPERtrax® Ghost - 1518
Battery Type:	12V10AH
Age Range:	2 – 6 Years
Max. Weight:	65 lbs
Product Size:	51”L x 28”W x 24”H
Avg. Speed:	2 – 3 MPH
Charging time:	8-12 hrs (max) – Minimum 1 Charge per month
Avg. Use Time:	1-2 Hrs (depending on use)
Remote Battery:	2 - AA (not included)

IMPORTANT

<ul style="list-style-type: none"> Assembly of car and charging of battery is only to be done by an adult.  	<ul style="list-style-type: none"> WARNING!! NOT TO BE USED ON STREETS or IN TRAFFIC.
<ul style="list-style-type: none"> Never modify the electric circuit system or tamper with electric system. Can cause permanent damage. 	<ul style="list-style-type: none"> Please check the product regularly for any loose parts or wires to ensure proper operation.
<ul style="list-style-type: none"> Adult supervision is recommended during operation by child to avoid injury. Safety equipment is recommended. 	<ul style="list-style-type: none"> Please make sure that the child uses caution to avoid falls and collisions which could cause injury to the child or third party.
<ul style="list-style-type: none"> Do not pick up vehicle by steering wheel. 	<ul style="list-style-type: none"> Do not pick up battery by wires or charger.
<ul style="list-style-type: none"> Keep all plastic bags out of the reach of young children. 	<ul style="list-style-type: none"> Not recommended for children under the age of 2 yrs. due to small parts that could cause a choking hazard.
<ul style="list-style-type: none"> Battery must be charged for a minimum of 8-12 hours prior to first use of the car to avoid damage to the battery. <u>Do NOT charge for more than 12 hours.</u> Power switch must be in “off” position when charging. 	<ul style="list-style-type: none"> Battery charger should be examined for damage prior to each use. It is important to inspect the cord and both ends for damage. If damage is found, DO NOT USE THE CHARGER! Contact us for replacement charger.
<ul style="list-style-type: none"> Please retain instruction manual for future reference. 	<ul style="list-style-type: none"> Please retain packaging in the event it is necessary to return.

If the charger is plugged into the charging port, the car will not power up regardless if the charger is plugged into the wall outlet or not.

PARTS LIST:

1	Car Body	2	Hood Emblem	3	Windshield
4	Rearview Mirrors	5	Steering Wheel	6	Seat
7	Rear Body Support	8	Front Body Support	9	Motor/Gearbox
10	Rear Wheels/Tires	11	Front Wheels/Tires	12	
13	Hubcap center caps	14	Wheel Bushings	15	Washers
16	Lock Nut	17	Upper door windows		

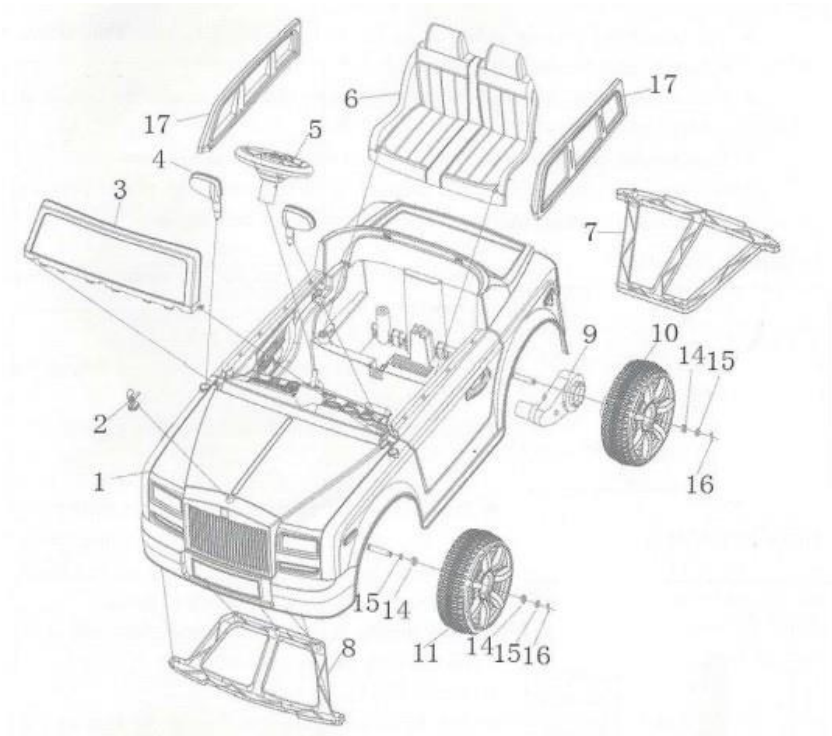

[All assembly videos can be found on YouTube under SUPERtrax](#)

ASSEMBLY INSTRUCTIONS:

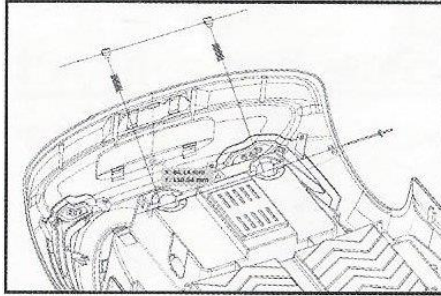

Step 1 - Install rear axle:

Turn car upside down. As seen in the photo above, insert the springs into the spring pockets toward the rear of the car. Place plastic spring caps over the springs so that the open end is facing up. Slide rear axle through the hole in the side of the body while pushing down the plastic spring caps far enough to line up the holes. This will allow you to feed the axle completely through to the opposite side.

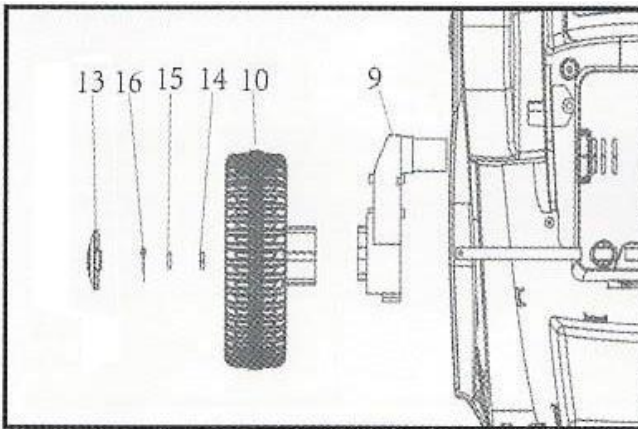

Step 2 - Install rear wheel/gearbox assembly:

Turn car right side up. Place the motor/gearbox marked with an "R" onto the axle on the right side of the car (facing the car from the rear). While sliding the gearbox onto the axle, feed the electrical connector and motor through the hole in the body. Next, insert a wheel bushing into each side of the wheel, slide the rear wheel onto the axle followed by the wheel bushing & washer. Thread on lock nut until snug. Finally, install the wheel cover center cap. **Repeat steps for left side of car.**

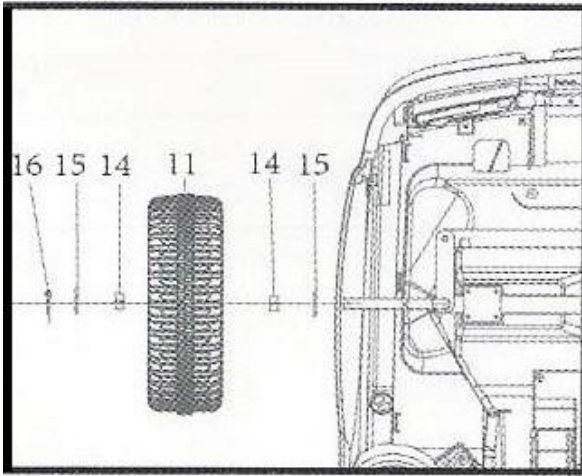

Step 3 – Install front wheels:

Slide a washer on the end of the front axle. Insert a wheel bushing into each side of the front wheel. Slide wheel onto the axle, making sure that the wheel bushings stay in place, followed by a washer. Thread on lock nut until snug. Finally, install the wheel cover center cap. **Repeat steps for opposite side of car.**

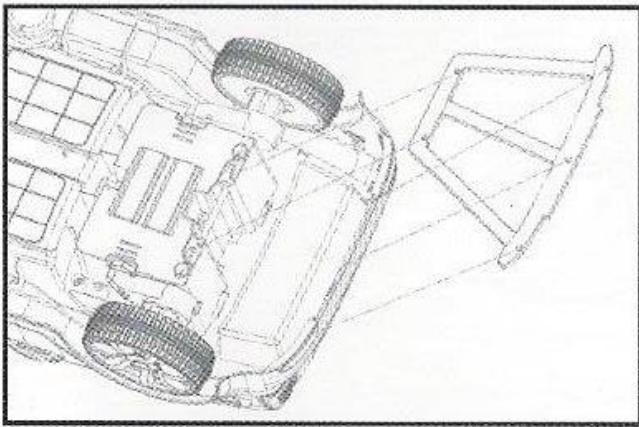

Step 4 – Install rear body support:

Turn car upside down. Line up rear body support as shown in photo above, ensuring that the holes in the rear body support line up with the screw posts in the body. Install screws through each hole in rear body support and tighten until snug. **Do not overtighten!**

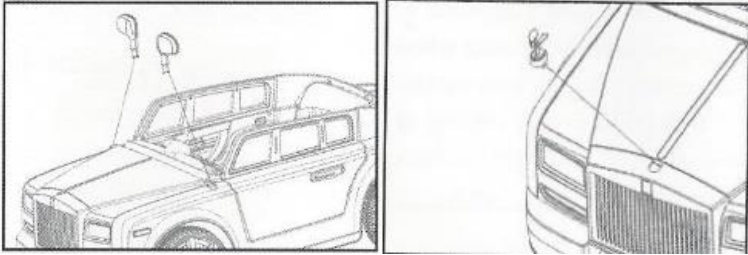

Step 5 – Install side mirrors & hood emblem:

Insert the mirrors into the holes in the body and press firmly down until they snap into place. Repeat steps for hood emblem.

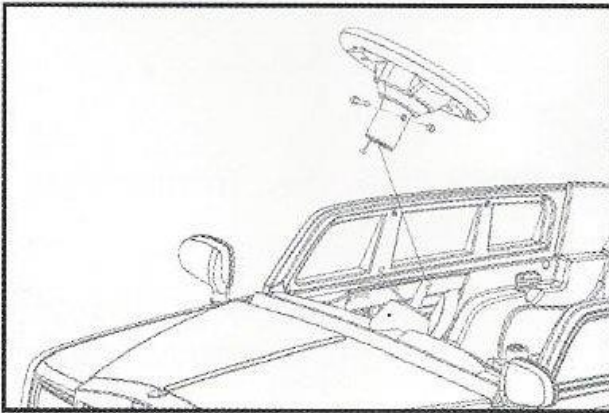

Step 6 - Install steering wheel:

Remove screw and nut from the shaft of the steering wheel. Connect electrical connection between the steering wheel and the wires from the car. Slide steering wheel onto the steering shaft. Align the screw hole in the steering shaft and the steering wheel and slide the bolt through the hole. Apply the nut to the end of the bolt and tighten until snug.

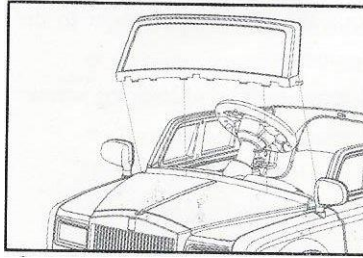

Step 7 - Install windshield:

Align the tabs on bottom of windshield with the tabs on body of the car and push down until you hear a click. Then insert the screws on both sides of the windshield (located by mirrors) to secure the windshield.

Step 8 – Connections in battery area:

Connect plastic electrical connector from the motor to the corresponding plastic electrical connector from the car. Make connection to both motors. Connect red wire to the positive (+) side of the battery. Connect black wire to the negative (-) side of the battery.

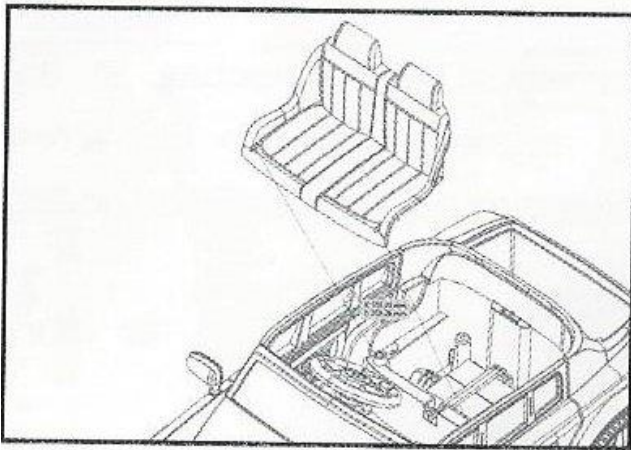

Step 9 – Install the seat:

Slip tabs on back of seat into the slots in the body of the car. Attach seat to body through the two holes located in the front corners of the seat with 2 screws.

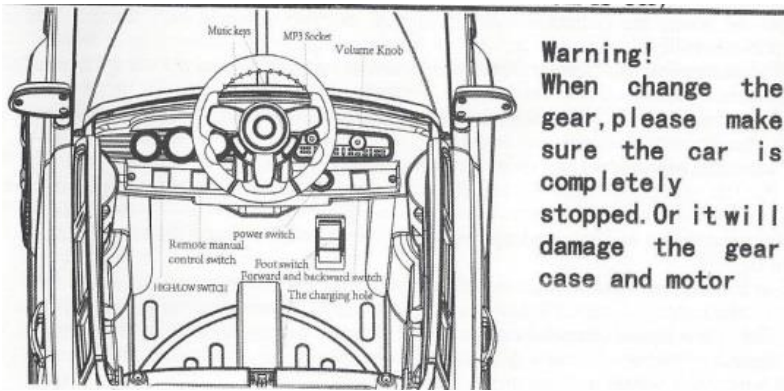

- 1) Power switch: turn the car on and off
- 2) Forward/backward switch: changes the direction the car moves from forward to reverse: To move the car forward, press the top of the switch down; To move the car backward, press the bottom of the switch down; Shift the switch to the middle, the car will stop
- 3) High/Low Switch: Press top of switch down for fast speed; Press bottom of switch down for slow speed.
- 4) Music Keys: press for sounds of music playing
- 5) MP3 socket: plug MP3 cable to play music from mobile or MP3 player
- 6) Foot Pedal: Applies power (speed) to the car: To move the car, press the foot pedal down; To brake or slow down the car, release the foot pedal
- 7) The charging hole: Located under the front of the seat.
- 8) Volume knob: Adjust level of music through the speaker.

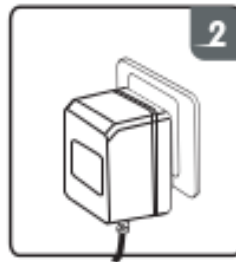
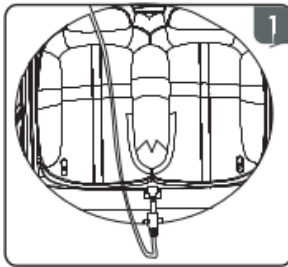

10. **Charging the battery:** The charging port is located just under the front portion of the seat. Plug the charger into the charging port first, then plug the charger into wall outlet. **BATTERY MUST BE CHARGED A MINIMUM OF 8 TO 12 HOURS AT LEAST ONCE PER MONTH. NEVER CHARGE FOR MORE THAN 12 HOURS.**

Please Note: As a safety precaution and to avoid damage to the charger, the car will not power up while charger port is plugged into the car.

BATTERY REPLACEMENT AND DISPOSAL:

The battery will eventually lose the ability to hold a charge. Depending on the amount of use, and varying conditions, the battery should operate for one to three years. Follow these steps to replace and/or dispose of the battery:

- Remove the cars seats
- Disconnect the battery connectors
- Remove the metal battery bracket
- Remove the battery cover
- Carefully lift the battery - you may want to wear protective gloves before removal - **Do Not** lift the battery by its connectors or cables
- Place the dead battery in a plastic bag
- Replace the battery and reconnect the connectors
- Replace the metal battery bracket
- Replace the seat



Remote Control Instructions: For the first time use of remote control or after replacing the battery, you need to sync the remote to the car.

- 1) Press the car-select button down until the remote indicator light is flashing, turn on car, and when the light stops flashing pairing has been successful.
- 2) Repeat if this does not happen.
- 3) Once paired for the first time, no need to pair remote for later use unless the batteries are changed in the remote.
- 4) Emergency brake. Press & hold stop button down to stop motion of the car immediately. Release the button to restore the normal functions of the car.



Forward



Backward



Turn Right



Turn Left

WARNING:

- Use only the rechargeable battery and charger supplied with your vehicle. **NEVER** substitute the battery or charger with another brand. Using another battery or charger may cause damage.
- **NEVER** modify the electric circuit system. Tampering with the electric system may cause permanent damage to the system.
- **Do not** allow direct contact between battery terminals.
- **Do not** allow any type of liquid on the battery or its components.
- Charge the battery in a well-ventilated area **ONLY**. Do not charge near or around flammable materials.
- **NEVER** pick up the battery by the wires or charger. Damage can occur to the battery and may cause a fire. Pick up the battery by the case **ONLY**.
- Charge the battery in a dry area **ONLY**.

Wash hands after handling.

- **Do not** open the battery. Battery contains lead acid and other materials that are toxic and corrosive.
- **Do not** open the charger. Exposed wiring and circuitry inside case could cause electric shock. **NEVER** allow a child to handle or charge the battery. Battery is heavy and contains lead acid (electrolyte).
- **Do not** drop the battery. Permanent damage to the battery could occur or cause serious injury
- Before charging the battery, check for wear or damage to the battery, charger, its supply cord and the connectors. **DO NOT** charge the battery if any damage to parts has occurred.
- **Do not** allow the battery to drain completely. Recharge the battery after each use or once per month if not used regularly.
- **Do not** charge the battery upside down.
- **Always** secure the battery with the bracket. Battery can fall out and injure a child if vehicle tips over.
- The **Power Switch** must be turned in the **OFF** position when charging.
- When the car begins to run slowly, recharge the battery.
- **Do not** charge battery for more than 12 hours.

GENERAL MAINTENANCE:

It is the parent's responsibility to check main parts of the toy before using. Regularly examine the car for potential hazards, such as damage to the battery, charger, cable or cord, and plug. Also, check that all screws are tightened throughout the car. In the event of such damage, the toy must not be used until that damage is repaired or replaced.

- Make sure the plastic parts of the vehicle are not cracked or broken.
- Occasionally use a lightweight oil to lubricate moving parts such as wheels.
- Park the vehicle indoors or cover it with a tarp to protect it from wet weather.
- Keep the vehicle away from sources of heat, such as stoves and heaters. Plastic parts may melt.
- Recharge the battery after each use. Only an adult should handle the battery. Recharge the battery at least once a month when not being used (12 hours max).
- Do not wash the vehicle with a hose. Do not wash the vehicle with soap and water. Do not drive the vehicle in rainy or snowy weather as water will damage the motor, electric system and battery.
- Clean the vehicle with a soft, dry cloth. To restore shine to plastic parts, use a non-wax furniture polish. Do not use car wax. Do not use abrasive cleaners.
- Do not drive the vehicle in loose dirt, sand or fine gravel which could damage moving parts, motors or the electric system.
- For extended times when the car will not be used, the power switch needs to be in the "off" position and the electrical connections should be disconnected from the battery.

TROUBLE SHOOTING GUIDE:

Problem	Possible Cause	Possible Solutions
Car will not move	<ol style="list-style-type: none"> 1. Battery voltage is low. 2. Battery connector or wires are loose. 3. Battery is damaged or dead. 4. Electrical box or motor is damaged 	Charge the battery Re-connect the battery connector to the car Replace battery Replace motor
The battery will not charge.	<ol style="list-style-type: none"> 1. Battery connector may have come apart or have a bad connection. 2. Battery charger plugged into a bad wall outlet. 3. Battery charger is damaged. 	Re-connect the battery connector to the car electrical connector Try another wall outlet Replace battery charger
Shortened battery life	Battery was not charged fully Battery is old	Charge battery fully Change battery
Some Noise and heat when charging battery	Chemical reaction	Normal
Low Speed	Battery is old Battery is low on charge Weight limit exceeded Uneven or uphill path Vehicle is being used in harsh conditions	Change the battery Charge the battery Do not exceed max weight limit Use on flat surfaces Avoid using car in harsh conditions
Noise coming from motor/gearbox	Gear in motor/gearbox broken	Call for replacement motor
The car shakes when moving	Bad Connection of the motor wires Possible motor failure	Reconnect wires Call for replacement motor
Car needs a push to go forward	Poor contact of wires and/or connectors "Dead Spot" on motor	Check that the battery connectors are firmly plugged into each other. If wires are loose around the motor, contact our service department A dead spot means the electric power is not being delivered to the terminal connection. Call our service department

Self-Resetting Breaker – The vehicle is equipped with a self-resetting breaker. In the event the power is tripped the breaker will reset itself in approximately one minute.

If you are unable to solve a problem, please feel free to contact us.

Phone: 402-477-0541 or Email: customerservice@rollinghillstrading.com